

**NEW MEDICAL OFFICE BUILDING**

**DOCTORS MEMORIAL HOSPITAL  
ADDENDUM NO. THREE**

**BONIFAY, FLORIDA  
AUGUST 22, 2024**

BID DATE: September 4, 2024  
BID TIME: 2:00 p.m. Central Time

The attention of all Bidders is directed to the following changes in the Drawings and Specifications, which amend and become part of them. It is requested that this Addendum be attached to the Specifications.

<b>Item 1:</b>  Addendum Three 08/22/24	<b>Drawings, Architectural Sheets, Sheet A-1.0, Floor Plan, Room 106 Conference,</b>  <b>Refer to West Wall and Call Out that Reads:</b> Flat screen television.  <b>ADD</b> Construction Note Symbol 1  <b>CHANGE Note to Read</b> Flat screen television by Owner, N.I.C.
<b>Item 2:</b>  Addendum Three 08/22/24	<b>Drawings, Architectural Sheets, Sheets A-3.0, A-5.0, A-5.1, and A-5.2</b>  <b>Refer to all Call Out Notes that Read:</b> Stone Veneer  <b>CHANGE to Read</b> Stone veneer as per specs installed over ½” thick scratch coat over zinc-coated galvanized steel, self-furring Diamond expanded metal lath over weather resistive non perforated asphalt saturated felt.
<b>Item 3:</b>  Addendum Three 08/22/24	<b>Drawings, Architectural Sheets, Sheets A-4.0, Roof Plan Notes, Roof Plan Note 1</b>  <b>CHANGE</b> Tapered rigid insulation over steel deck  <b>TO</b> Tapered rigid insulation <b>with average R Value equal to 30</b> over steel deck
<b>Item 4:</b>  Addendum Three 08/22/24	<b>Drawings, Architectural Sheets, Sheets A-5.0, A-5.1, A-5.2</b>  <b>Refer to Call outs that Read:</b> Single ply roof membrane over ½” coverboard over tapered rigid insulation.  <b>CHANGE to Read</b> Single ply roof membrane over ½” coverboard over tapered rigid insulation <b>system with average R Value equal to 30</b>
<b>Item 5:</b>  Addendum Three 08/22/24	<b>Drawings, Structural Sheet, Sheet S-1.1</b>  <b>SEE Revised Sheet S-1.1</b> attached to this addendum.
<b>Item 6:</b>  Addendum Three 08/22/24	<b>Specifications, Division II, Supplementary Instruction to Bidders, Section 1, Subsection 1-16, Mandatory Pre Bid Conference,</b>  <b>Subsection Title CHANGE</b> Mandatory <b>TO</b> Non-mandatory  <b>First Paragraph, Change to Read:</b>  <b>A Non-Mandatory Pre-Bid Conference <u>will</u> be held August 29, 2024 at 10:00 a.m., CT at</b>

**NEW MEDICAL OFFICE BUILDING**

**DOCTORS MEMORIAL HOSPITAL  
ADDENDUM NO. THREE**

**BONIFAY, FLORIDA  
AUGUST 22, 2024**

	<p>the Doctors Memorial Hospital located at 2600 Hospital Drive, Bonifay, Florida, for all suppliers, subcontractors, bidders, and any others who may have questions regarding this project.</p> <p><b>Second Paragraph ELIMINATE it in its entirety.</b></p>
<p><b>Item 7:</b></p> <p>Addendum Three 08/22/24</p>	<p><b>Specifications, Division III, Technical Sections</b></p> <p><b>ADD</b> Section 4B – Stone Veneer and Trim</p> <p>Specifications are attached to this addendum.</p>
<p><b>Item 8:</b></p> <p>Addendum Three 08/22/24</p>	<p><b>Specifications, Division III, Technical Sections, Section 8A, Glass, Glazing, Storefront, Curtain Wall, Subsection 8A-08 Glazed Aluminum Curtain Walls, Sub-sub Section 8 Products, Paragraph iii, Framing System Subparagraph (V)(c) Versoleil SunShade</b></p> <p><b>DELETE</b> Sub-paragraph (V)(c) in its entirety</p>

**END OF ADDENDUM THREE**

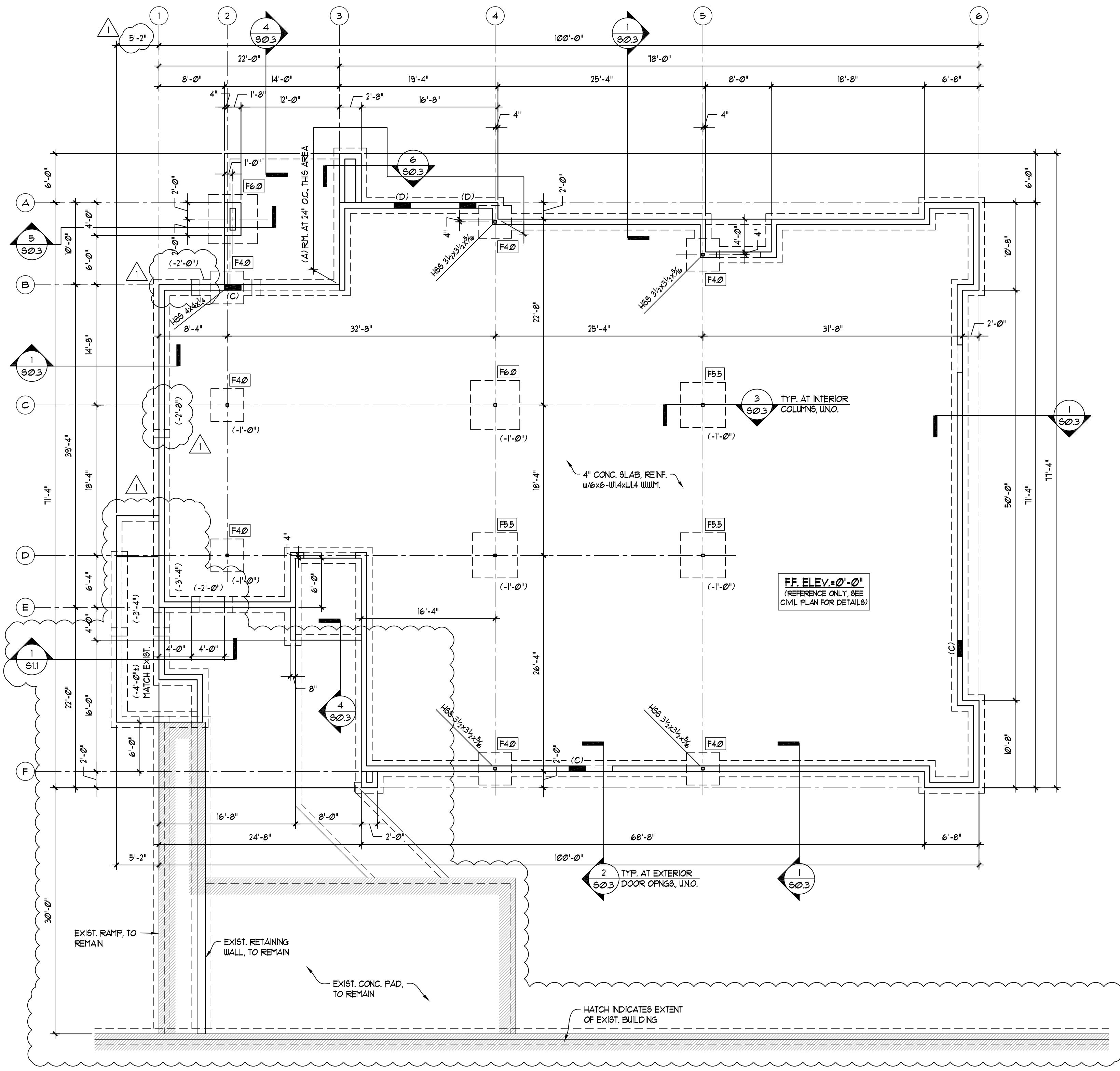

COLUMN FOOTING SCHEDULE	
MARK No.	FOOTING SIZE & REINF.
F3	3'-6" SQ. x 1'-4" DP. REINF. w/4-#5 EA. WAY, TOP & BOTT.
F4	4'-0" SQ. x 1'-4" DP. REINF. w/4-#5 EA. WAY, TOP & BOTT.
F5	5'-6" SQ. x 1'-6" DP. REINF. w/6-#5 EA. WAY, TOP & BOTT.
F6	6'-0" SQ. x 1'-6" DP. REINF. w/7-#5 EA. WAY, TOP & BOTT.

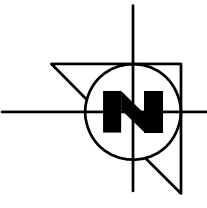

**FOUNDATION PLAN**  
1/8"=1'-0"

- NOTES:
- TOP OF ALL FOOTINGS -1'-4" BELOW FINISH FLOOR UNLESS NOTED OTHERWISE (UNO).
  - C.J. CONSTRUCTION JOINT, SEE DETAIL A/S01 S.J.+S.W. JOINT, SEE DET. B/S01.
  - SEE SHEET S01 FOR GENERAL STRUCTURAL NOTES.
  - FOUNDATION PLAN PLANE IS SHOWN AT APPROXIMATELY TOP OF SLAB ELEVATION.
  - ALL STEEL COLUMNS SHOWN THIS SHEET ARE HSS 4x4x1/4 w/ TYPE 1 BASE, UNO.
  - CONTRACTOR VERIFY ALL CLOUDED DIMENSIONS NOTED THUSLY, 5'-0"

- REINF. MASONRY NOTES**
- EXTERIOR 8" CMU WALLS:
    - USE (A) RM. AT 4'-0" O.C. MAX. AT ALL EXTERIOR WALL LOCATIONS, AND AT ALL WALL CORNERS AND INTERSECTIONS, UNO.
    - OPENINGS UP TO AND INCLUDING 6'-4" WIDE, CLEAR, USE (B) RM. EA. SIDE OF OPENING, UNO.

REINFORCED MASONRY (RM) DESCRIPTIONS	
MARK No.	DESCRIPTION
(A)	8"x8" RM. FROM FOUNDATION TO BOND BEAM AT TOP OF WALL. FILL EACH CELL WITH CONCRETE FULL HEIGHT. REINFORCE EACH CELL WITH 1-#5 CONT. VERT. DOUCL. REINF. TO FOUNDATION AND LAP WITH BOND BEAM REINF. AT TOP OF WALL.
(B)	8"x8" RM. FROM FOUNDATION TO BOND BEAM AT TOP OF WALL. FILL EACH CELL WITH CONCRETE FULL HEIGHT. REINFORCE EACH CELL WITH 1-#5 CONT. VERT. (2-#5 VERT. TOTAL) DOUCL. REINF. TO FOUNDATION AND LAP WITH BOND BEAM REINF. AT TOP OF WALL.
(C)	8"x24" RM. FROM FOUNDATION TO BOND BEAM AT TOP OF WALL. FILL EACH CELL WITH CONCRETE FULL HEIGHT. REINFORCE EACH CELL WITH 1-#5 CONT. VERT. (3-#5 VERT. TOTAL) DOUCL. REINF. TO FOUNDATION AND LAP WITH BOND BEAM REINF. AT TOP OF WALL.
(D)	8"x24" RM. FROM FOUNDATION TO BOND BEAM AT TOP OF WALL. FILL EACH CELL WITH CONCRETE FULL HEIGHT. REINFORCE EACH CELL WITH 1-#1 CONT. VERT. (3-#1 VERT. TOTAL) DOUCL. REINF. TO FOUNDATION AND LAP WITH BOND BEAM REINF. AT TOP OF WALL.

- GENERAL REINFORCED MASONRY NOTES**
- RM'S SHOWN ON PLANS ARE FOR STRUCTURAL WALLS. REINFORCE NON-STRUCTURAL WALLS WITH 8"x8" RM'S w/1-#5 VERT. AT ALL CORNERS, INTERSECTIONS, OPENINGS (SUCH AS DOORS, WINDOWS, LOUVERS, ETC.) AND ENDS OF WALLS.
  - SEE DETAIL D/S02 FOR TYPICAL RM. INSTALLATION.

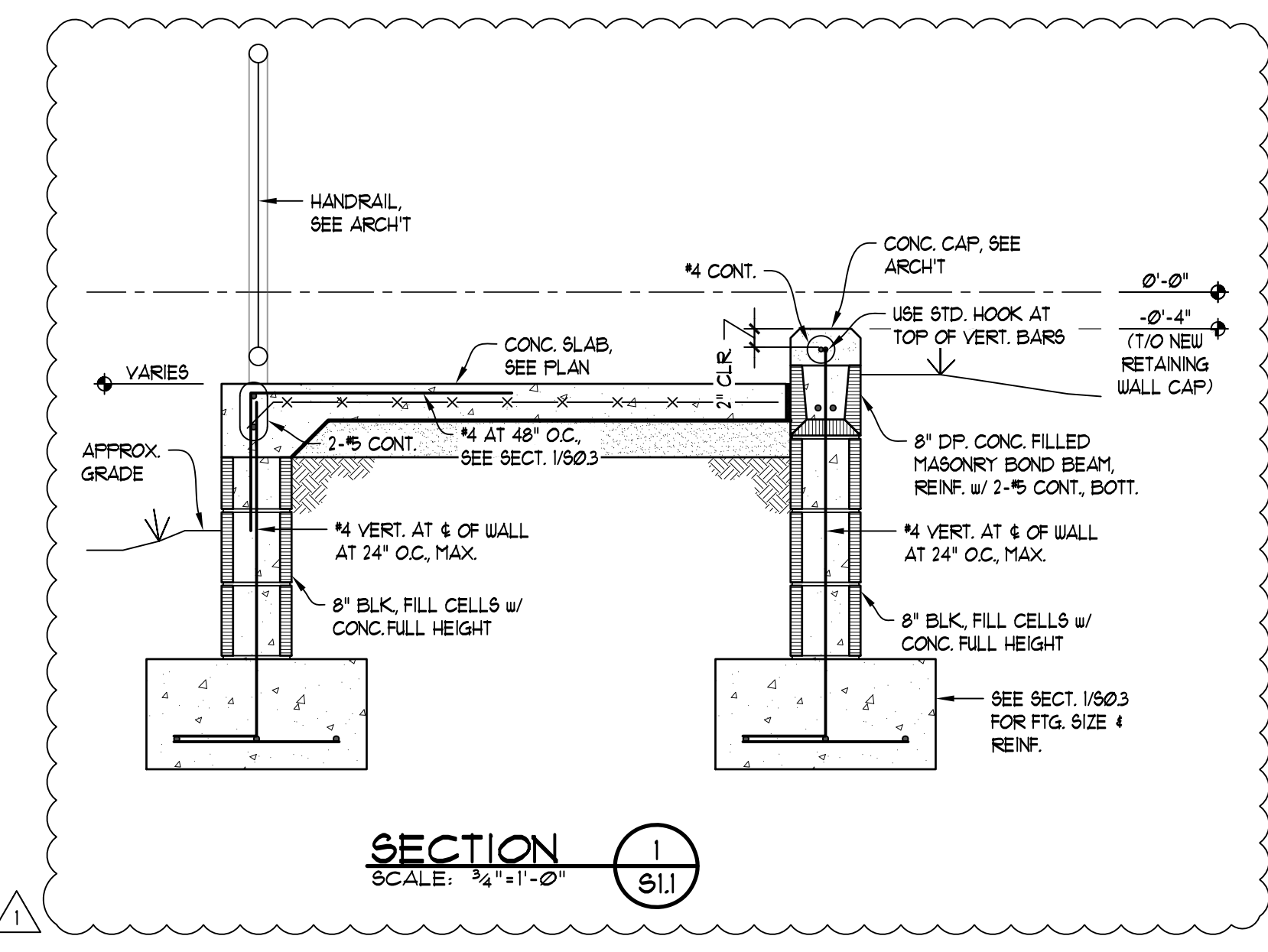

THIS DRAWING & SPEC. SHOWN IS THE PROPERTY OF DONOFRO ARCHITECTS & ASSOCIATES, INC. FOR THE USE OF THIS PROJECT ONLY. NO REUSE OR REPRODUCTION OF THIS DRAWING IS PERMITTED WITHOUT THE WRITTEN CONSENT OF DONOFRO ARCHITECTS & ASSOCIATES, INC. P.O. BOX 861 MARIANNA, FL 32447

**DONOFRO ARCHITECTS**  
2910 CALEDONIA ST.  
MARIANNA, FL 32446  
OFFICE: (850) 482-5261

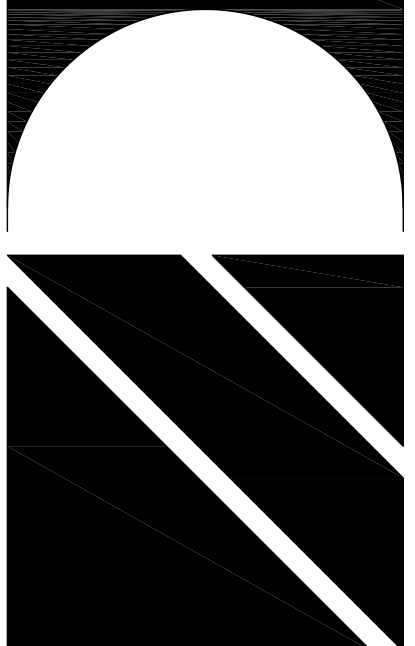

FOUNDATION PLAN  
NEW MEDICAL OFFICE BUILDING  
FOR  
**DOCTORS MEMORIAL HOSPITAL**  
2800 HOSPITAL DR. BONIFAY, FLORIDA

JOB NUMBER: M-2022-03  
DATE: JULY 19, 2024  
DRAWN BY: P.D.J.G.  
CHECKED BY: B.B.J.

SHEET No.  
**S-1.1**

## **SECTION 4B**

### **STONE VENEER AND TRIM**

#### **PART 1 - GENERAL**

##### **1.1 SUMMARY**

A. Section includes:

1. Manufactured Stone Veneer and Architectural Precast Trim products
2. Manufactured Thin Brick Veneer and Architectural Precast Trim products

##### **1.2 RELATED SECTIONS**

Drawings and General Provisions of the Contract, including General and Supplementary Condition and Division 1 Specification Sections, apply to this Section.

- A. Section 03 30 00 - Cast-In-Place Concrete
- B. Section 04 20 00 - Masonry Units
- C. Section 04 71 00 - Thin Brick Masonry Veneer
- D. Section 05 40 00 - Cold-Formed Metal Framing
- E. Section 06 10 00 - Rough Carpentry
- F. Section 06 11 20 - Framing and Sheathing
- G. Section 07 62 00 - Sheet Metal Flashing & Trim
- H. Section 07 90 00 - Joint Protection

##### **1.3 REFERENCES**

A. ICC Evaluation Service - International Code Council (ICC-ES); Birmingham, Alabama 800-423-6587

B. American Society for Testing and Materials International (ASTM); Philadelphia, Pennsylvania. (215) 299-5420

Test Methods:

- ICC-ES AC-51, Acceptance Criteria for Precast Stone Veneer
  - ASTM C67-03ae01, Standard Test Methods for Sampling and Testing Brick and Structural Clay Tile
1. ASTM C567-05a - Standard Test Method for Determining Density of Structural Lightweight Concrete
  2. ASTM C39-99ae1, Standard Test Method for Compressive Strength of Cylindrical Concrete Specimens
  3. ASTM C192-81 Standard Practice for Making and Curing Concrete Test Specimens in the Laboratory
  4. ASTM C109/C109M-02 Standard Test Method for Compressive Strength of Hydraulic Cement Mortars
  5. ASTM C190-85, Standard Test Method for Tensile Strength of Hydraulic Cement Mortars
  6. ASTM C348-86, Standard Test Method for Flexural Strength of Hydraulic Cement Mortars

7. ASTM C482-02, Standard Test Method for Bond Strength of Ceramic Tile to Portland Cement Paste
8. ASTM C1670/C1670M-20a Standard Specification for Adhered Manufactured Stone Masonry Veneer Units

C. Masonry Veneer Manufacturers Association (MVMA); Herndon, Virginia. (703) 713-1900

#### **1.4 SUBMITTALS**

A. Submit following submittals in accordance with Section 01300.

B. Product Data: For each variety of stone, stone accessory, and manufactured product. Manufacturer's specification and data sheets for each type of product indicated, Including:

1. Samples for Verification: For each stone type indicated, provide at least two Samples in each set and show the full range of color and other visual characteristics in completed Work.

- i. A 2'x2' approximate portable size sample board should be submitted for each product specification.

- ii. Include manufacturer's color selection charts showing the full range of colors available for each stone veneer product exposed to view.

2. Shop Drawings: Provide detailed cut sheets of Manufactured Stone products and fastening methods to be used.

3. Manufacturer's Certificate: Certify that products meet those requirements set forth in the ICC ES Testing Requirements for Manufactured Stone Masonry, including all related product testing and building codes.

4. Closeout Submittals: Submit following items:

1. Maintenance Instructions

2. Storage and Handling Recommendations

3. Quality Stone Veneer Installation and Product Warranties

#### **1.5 QUALITY ASSURANCE**

A. Qualifications: Company specializing in manufacturing and installing manufactured stone veneer.

B. Single Source Accountability: Obtain manufactured stone, thin brick and/or trim precast from a single turnkey manufacturer & installer with no less than twenty-five years of documented experience in manufacturing and installation of materials depicted in this submittal. Manufacturer and installer shall have completed at minimum ten projects of similar scope.

Quality Stone Veneer, Inc. Qualifications:

1. Has been in business over 40 years, founded in 1976.

2. Has 25 years' experience in the manufacturing of stone veneer.

3. Provides an OSHA certified project field manager.

4. Provides extensive company and jobsite safety programs including, but not limited to: scaffold

safety, fall protection, personal protective equipment and an in house safety incentive program for all employees and subcontractors.

5. Has a 50 year product warranty.
6. Follows all updated guidelines set forth by the Masonry Veneer Manufacturer's Association.
7. Services a national footprint across the United States.

C. Installation Qualifications: Installer must have minimum 5 years' experience in the successful installation and completion of manufactured stone masonry work of similar scope to the given project. Installer must be able to provide a jobs and references if requested by project team or architect.

D. Mockups: Build on-site mockup to demonstrate aesthetic effects and to set quality standards for materials and execution. Mock up to serve as final verification and approval on stone style, stone color, installation accessories, precast accessories and grout. Mockup can either be installed on a section of the project determined by the GC/Owner, or installed on a separate freestanding mock up structure provided by the GC/Owner.

1. Build mockups for typical exterior wall in sizes approximately 48 inches long by 48 inches high by full thickness.
2. Include manufactured stone sill, banding, and accessories as shown or required.
3. Protect and retain sample as a basis for approval of completed manufactured stone work. Approved sample may be incorporated into completed work.
4. Do not proceed with remaining work until workmanship, color, and sheen are approved by Architect.

E. Product Testing Certifications: Quality Stone Veneer ICC-ES Evaluation Report.

F. Preconstruction Meeting: Precon meeting to be held between Quality Stone Veneer local representative and project team to verify all items pertaining to the given scope of work including but not limited to: samples, application method, installation products, site conditions and schedule.

1. Attendance: General Contractor, Architect/Owner's Representative, Quality Stone Veneer local representative

G. **Warranty:** Single Source Warranty by Quality Stone Veneer, Inc.

1. Quality Stone Veneer, Inc. Fifty (50) Year Product Warranty
2. Quality Stone Veneer, Inc. Ten (10) Year Precast Accessory Warranty
3. Quality Stone Veneer, Inc. One (1) Year Installation Warranty

## 1.6 SUSTAINABLE DESIGN QUALITY ASSURANCE

A. Sustainable Design Requirements

1. Evaluation to the following green codes or standards:
  - i. 2016 California Green Building Standards Code (CALGreen), Title 24, Part 11 2015, 2012, and 2008 ICC 700 National Green Building Standard™
2. Regional Materials: Furnish materials extracted, processed, and manufactured within 500

miles of project site.

3. Certify the source for local and regional materials and distance from Project Site.

### **1.7 DELIVERY, STORAGE & HANDLING**

A. Delivery: Coordination of onsite delivery to be planned in advance between Quality Stone Veneer Shipping Department and on site project team to determine staging area and placement of materials in order to avoid work delays.

B. Store and handle products in manufacturer's unopened packaging until ready for installation in order to prevent damage from moisture, temperature or outside forces.

C. Store cementitious materials on elevated platforms, under cover, and in a dry location. Do not use cementitious materials that have become damp.

### **1.8 SITE CONDITIONS**

A. Cold Weather Requirements: Do not build on frozen substrates. Remove and replace units damaged by frost or freezing conditions. Installation only to be performed when air temperature is above 40 F for a minimum of 48 hours.

1. During conditions where this temperature cannot be maintained, tenting with waterproof sheeting and heating is an approved method for stone installation whereby the air temperature can be maintained to allow for stone installation and curing, as recommended in section "2104.3 Cold Weather Construction" of the International Building Code.

B. Hot Weather Requirements: When ambient temperature exceeds 100 F, or 90 F with a wind velocity greater than 8 mph, do not spread mortar beds more than 48 inches ahead of masonry. Set masonry units within one minute of spreading mortar.

C. Follow all manufacturers' recommended environmental conditions to ensure proper installation and finish results.

1. Protection of Stone Masonry: During construction, cover tops of walls, projections, and sills with waterproof sheeting at end of each day's work.

2. Protect base of walls from rain-splashed mud and mortar splatter using coverings spread on the ground and over the wall surface.

3. Protect sills, ledges, and projections from mortar droppings.

4. Protect surfaces of window and door frames, as well as similar products with painted and integral finishes, from mortar droppings.

5. Turn scaffold boards near the wall on edge at end of each day to prevent rain from splashing mortar and dirt on completed stone masonry.

### **1.9 COORDINATION**

A. Advise installers of other work about specific requirements for placement of flashing and similar items to be built into stone masonry. Coordinate stone veneer assemblies with rain drainage work,

flashing, trim, and construction of studs, soffits, and other adjoining work to provide secure and water-tight installation.

## **PART 2 – PRODUCTS**

### **2.1 MANUFACTURER**

A. Basis of Design Manufacturer: **Quality Stone Veneer, Inc.**

**Corporate Office: 50 Refton Road, Refton, PA 17568**

- Phone: 717-786-3229
- Fax: 717-806-0961
- Email: Estimating@QualityStoneVeneer.com
- Web: QualityStoneVeneer.com

B. Product: Style/Color as selected by the Architect/Owner

1. Source Limitations for Stone: Obtain each variety of stone, regardless of finish, from single manufacturer, whether specified in this Section or in another Section of the Specifications, with resources to provide materials of consistent quality in appearance and physical properties.

C. Basic Use

1. Interior or exterior walls of new construction.
2. Remodeling and redecorating of existing walls.
3. Fireplaces: around openings, hearth, exterior chimney finish, or chase finish.

C. Substitutions: Not Permitted.

### **2.2 STONE VENEER**

A. Manufactured Stone Veneer:

1. Color/Profile: **Conestoga**

B. Manufactured Thin Brick Veneer (If Applicable)

1. Color/Profile: **N.A.**

C. Precast Stone Accessories

1. Color/Finish: **N.A.**

D. Mortar

1. Color/Joint Style: **T.B.D.**

### **2.3 PROPERTIES**

A. Veneer Unit Properties: Manufactured stone veneer units and accent pieces consisting of Portland cement, lightweight aggregates, and mineral oxide pigments.

1. Compressive Strength: ASTM C 192, not less than 1800 psi.



2. Sheer Bond, Type S Mortar and Backing: ASTM C 482, min 50 psi.

3. Freeze-Thaw: ASTM C 67, less than 3% weight loss

4. Fire Hazard Test: UL Standards met, 0/0 Flame spread

5. Maximum Veneer Unit Weight: 15 lbs. /square foot

B. Quality Stone Veneer product is manufactured utilizing a mix of Portland cement, light weight aggregates, minerals, and powdered dyes. Quality Stone Veneer product is cast from natural stone profiles by hand in a wide variety of textures and styles to create a unique, natural finish.

C. Note: Manufactured stone does not add strength to load-bearing capacity of wall. Stone should not be used in below-water applications. Product is intended for interior or exterior nonstructural lightweight veneer facing on masonry, metal, or frame construction for architectural beauty.

## **2.4 MORTAR**

### **A. Mortar**

1. Cement: Any cement complying with ASTM C270

2. Sand: ASTM C144, natural sand

3. Color: As selected by Architect and Owner

4. Water: Potable

### **B. Admixtures**

1. Bonding Agent: Concrete Bonding Adhesive per ASTM C1059, formulated for permanently bonding new concrete or plaster to old concrete.

C. Mortar should be mixed with the appropriate volume of sand and water, as per ASTM C270. Place approximately one-half the estimated amount of water into the mixer, followed by one-half of the sand, and all of the cement. Add balance of sand and gradually add remaining water to obtain the desired working consistency. Mix all material 3 to 5 minutes in a mechanical mixer.

### **D. Pre-mix Mortar/Sand**

1. Premixed sand/mortar in a bagged product, with a contractor-grade polymer modified mortar designed for stone veneer applications

2. Mix per manufacturer's recommendations.

## **2.5 RELATED MATERIALS**

A. Weather Resistive Barrier: ASTM D 779, Type 1, Grade "D", non-perforated asphalt saturated felt paper.

B. Self-adhered Flashing: Grace Vycor, 25 mil, cold applied, self-adhering membrane consisting of a 3 mil polyethylene film coated on one side with a 22 mil layer of rubberized asphalt adhesive. Used for all openings in framed walls for completing a weather resistive barrier, including windows, doors, MEP penetrations, and as required per code.

C. Ice and Water Shield: WIP 100 by Carlisle WIP products consisting of a 55-mil flexible rubberized

asphalt, fiberglass-reinforced membrane used as an underlayment on critical concrete or masonry block areas before wire lath and stone installation. Such areas include masonry chimneys above rooflines, and areas of poured concrete or block walls where moisture drainage will be critical to minimize efflorescence.

D. Drip Cap: Minimum 26 Gauge Galvanized Metal drip flashing as needed, manufactured with 3.5" nailing flange as required by IBC 2510 with  $\frac{7}{8}$ " ground description; in standard manufacturers' color selection.

E. Weep Products: Use one of the following unless otherwise indicated over framed construction:

a. Vinyl Foundation Weep Screed: manufactured with 3.5" nailing flange as required by IBC 2510 with  $\frac{7}{8}$ " ground description; in standard manufacturers' color selection.

b. Metal Foundation Weep Screed: G60 Galvanized Weep Screed to ASTM A653 to a minimum of .0172 inch, manufactured with 3.5" nailing flange as required by IBC 2510 with  $\frac{7}{8}$ " ground description.

c. Subject to compliance with code requirements, provide drip cap per 2.3.B above at designated weep areas and product indicated below by Masonry Technology Incorporated:

i. Product: Sure Cavity Wall Opening Weeps™ (WOW 9095)

ii. Spacing at 12" centers on galvanized drip cap to form weep openings.

F. Expanded Metal Lath: 2.5 lb. /sq. yd., self-furring, diamond-mesh lath complying with ASTM C 847. Fabricate from structural-quality, zinc-coated (galvanized) steel sheet complying with ASTM A 653/A 653M, G60.

G. Cavity Drainage Materials

1. Ventilated rainscreen: high density polyethylene sheet, dimpled and grooved to provide drainage and ventilation on both sides of sheet.

a. Product: Keene Driwall Rainscreen 10mm

2. Provide weep openings at head of windows, doors, and other openings using the following by Masonry Technology Incorporated:

a. Product: Sure Cavity Wall Opening Weeps™ (WOW 9095)

b. Spacing at 12" centers on galvanized drip cap to form weep openings

3. Casing Bead: E-Z Bead™ Vinyl Casing Bead by Amico Industries with a built-in flexible strip for uniform spacing around window and door frames.

H. Lath Attachment Devices: Material and type required by ASTM C 1063 for installations indicated.

## 2.6 TECHNICAL DATA

1. Applicable standards: Professional Service Industries, Inc. - Project No. 812-50301.

A. Product thickness .15 ft.

- B. Density (lbs. per cu. ft.) 82.2
- C. Temperature hot side (F) 95 degrees
- D. Temperature cold side (F) 55 degrees
- E. Average mean temperature (F) 75 degrees
- F. Thermal conductivity (k) 1.569
- G. Thermal resistance (r) 1.148
- H. Absorption (24 hours) 15.1%

2. Applicable standards: Underwriter's Laboratories, Inc. - Project No. 05CA22150

- A. (CFS) Calculated Flame Spread 0
- B. (FSI) Flame Spread Index 0
- C. (CSD) Calculated Smoke Developed 5.9
- D. (SDI) Smoke Developed Index 5

### **PART 3 - EXECUTION**

#### **3.1 EXAMINATION**

1. Installation is not to begin until all substrates have been properly prepared prior to stone installation, including necessary flashings, transitions, flatwork and penetrations in stone areas.
2. Establish lines, levels, and coursing. Protect from disturbance.
3. Commencement of work by installer is acceptance of substrate.
4. Installation is not to occur where overhead work is taking place at any time.

#### **3.2 PREPARATION FOR VENEER**

A. Install in accordance with Manufacturer's instructions, that being the most recent version of the Masonry Veneer Manufacturers Association (MVMA) Installation Guide found at [www.masonryveneer.org](http://www.masonryveneer.org).

1. Install one layer of weather resistive barrier (WRB) over the wall system, flashing properly around windows, doors, and other penetrations with 6" self-adhered flashing.
2. Verify that all items built in under other Sections are properly located and installed, including those set forth for stone veneer.
3. Install lath per installation guide and over masonry backup to comply with ASTM C 1063.
4. Apply a ½" thick scratch coat of mortar over the metal lath.

#### **3.3 INSTALLATION**

- A. Erect stone veneer in accordance with manufacturer's instructions at [www.qualitystoneveneer.com](http://www.qualitystoneveneer.com).
- B. Adjust layout so that color variations between individual adjacent pieces are not visually distinct. When installing stone, achieve a balanced pattern of shapes and colors by mixing the various sizes and textures of stone, and mixing stones from different boxes throughout the installation.

C. Stones should be installed with uniform size grout joints. A consistent  $\frac{3}{8}$ " or less space around the stones is desirable.

D. Stones should be cut with a wiremouth nippers, brick hammer, or with a diamond saw blade. Cut edges should be turned so they are not visible and the edges are concealed with mortar when grouting.

E. A mason's trowel should be used to apply a  $\frac{1}{2}$ " thick even layer of mortar to the stone back, scraping against the raked back to ensure proper bonding to the wall. A second layer of mortar should be used to create a beveled mud bed at all stone edges, using the edge of the trowel to create this bed. The stone should be pressed firmly into place and then a gentle wiggling action to ensure a good bond. The mortar should squeeze out around the edges of the stone and allowed to set until dry and crumbly.

F. After stones are set in the wall, the jointed should be raked out prior to jointing. A grout bag should be used to fill the joints with mortar forcing grout into any voids. The joints should be allowed to set until dry and crumbly, and then struck with a metal striking tool. After striking the joints, a whisk broom should be used to smooth the joints and clean away loose mortar from the joints and stone face.

### **3.4 FIELD QUALITY CONTROL**

A. Fabricator's Field Service: Engage a manufacturer-authorized field representative to test and inspect completed stone veneer panel installation, including accessories.

B. Stone Veneer wall panels will be considered defective if they do not pass tests and inspections.

C. Reference: ASTM C1670/C1670M-20a

### **3.5 CLEANING, MAINTENANCE AND PROTECTION**

A. Remove and replace stone masonry of the following description:

1. Broken, chipped, stained, or otherwise damaged stone. Stone may be repaired if methods and results are approved by architect.
2. Defective joints.
3. Stone masonry not matching approved samples and mockups.
4. Stone masonry not complying with other requirements indicated.

B. Cleaning

1. Most applications require no maintenance. The use of a high quality waterproofing sealer is recommended on any Quality Stone surface, but especially on those exposed to severe freezing or thawing, excessive moisture, or conditions which could discolor or stain the stone. A sealed surface is much easier to clean than an unsealed surface. We recommend that consumers have a sealant such as DECO 30 applied to Quality Stone Veneer.

2. Applications where dirt or dust may accumulate can be washed occasionally using a garden hose and soft bristle brush. Do not use a wire brush. Use mild soap or detergent and water; rinse immediately with fresh water.

- i. To clean dirt or other particles from the stone, use a granulated type detergent mixed with water and a soft bristle brush.

ii. Use nonmetallic tools in the cleaning operations; do not use pressure washing nor an acidic cleaner on the manufactured products as this may damage or discolor the stone.

3. Do not attempt to clean with acid or acid based products or Power Washer.

i. Efflorescence is normal and common in all masonry products and easily remedied. To remove, allow stone to dry. Scrub with stiff bristle brush and clean water. If efflorescence is still noticeable, scrub with solution of 50% household white vinegar and 50% water and rinse thoroughly.

4. Salt and Calcium Chloride Products: Do not use any of these products on areas adjacent to a stone veneer product.

**END OF SECTION**